

MountingInstructions

English	It is very important to follow these installation and operating instructions exactly. We cannot accept any responsibility for problems arising out of a failure to follow the installation and operating instructions.
Nederlands	Het is van belang dat u onderstaande montage- en bedieningsinstructies nauwgezet uitvoert. Wij aanvaarden geen verantwoordelijkheid voor het niet of verkeerd opvolgen van de montage- en bedieningsinstructies.
Français	Il est important de suivre minutieusement les instructions de montage et d'emploi ci-contre. Nous n'assumons aucune responsabilité si les instructions de montage et d'emploi ne sont pas suivies ou si elles sont mal suivies.
Deutsch	Bitte lesen Sie die nachstehenden Montage- und Bedienungshinweise sorgfältig durch. Wir übernehmen keine Haftung für den Fall, dass nicht korrekt nach den Montage- und Bedienungshinweisen gehandelt wurde.
Dansk	Det er meget vigtigt, at De følger monterings- og brugsanvisningen nøje. Vi kan ikke påtage os noget ansvar for problemer, som følger af at monterings- og brugsanvisningen ikke er fulgt eller ikke er fulgt korrekt.
Norsk	Det er svært viktig at disse installasjons- og brukerveiledningene følges nøye. Vi tar ikke ta på oss ansvar for problemer som følge av at disse installasjons- og brukerveiledningene ikke er fulgt.
Svenska	Det är mycket viktigt att du följer denna monterings- och bruksanvisning noga. Vi kan inte påta oss något ansvar för problem som uppkommer ur underlåtenhet att följa monterings- och bruksanvisningen.
Suomi	On erittäin tärkeää seurata tarkasti näitä asennus- ja käyttöohjeita. Emme voi ottaa vastuuta ongelmista, jotka aiheutuvat puutteellisesta asennus- ja käyttöohjeiden seuraamisesta.

Information

English	If you would like more information and/or you are having problems, please contact the dealer where you bought your Luxaflex® product or go to www.luxaflex.com
Nederlands	Mocht u verder nog vragen en/of problemen hebben richt u zich dan alstublieft tot uw dealer waar u uw Luxaflex® product gekocht heeft. Of ga naar www.luxaflex.com
Français	Si vous souhaitez de plus amples informations et/ou si vous avez des problèmes, contactez le concessionnaire chez qui vous avez acheté votre produit Luxaflex® ou consultez le site www.luxaflex.com
Deutsch	Bei Fragen oder Problemen wenden Sie sich bitte an den Händler, bei dem Sie Ihr Luxaflex®-Produkt gekauft haben, oder besuchen Sie die Website www.luxaflex.com
Dansk	Hvis De ønsker flere oplysninger og/eller har problemer: Kontakt den forhandler, Luxaflex®-produktet er købt hos, eller gå til www.luxaflex.com
Norsk	Hvis du vil ha mer informasjon, og/eller hvis du har problemer, må du ta kontakt med forhandleren du kjøpte Luxaflex®- produktet fra, eller gå til www.luxaflex.com
Svenska	Om du är intresserad av mer information och/eller har problem, var vänlig att kontakta återförsäljaren som du köpte din Luxaflex®-produkt av, eller besök www.luxaflex.com
Suomi	Jos haluat saada lisätietoja ja/tai sinulla on ongelmia, ota ystävällisesti yhteyttä jälleenmyyjään, jolta ostit Luxaflex® tuotteesi tai mene osoitteeseen www.luxaflex.com



window styling

MountingInstructions

Plissé hordeur Allure

OPTIES

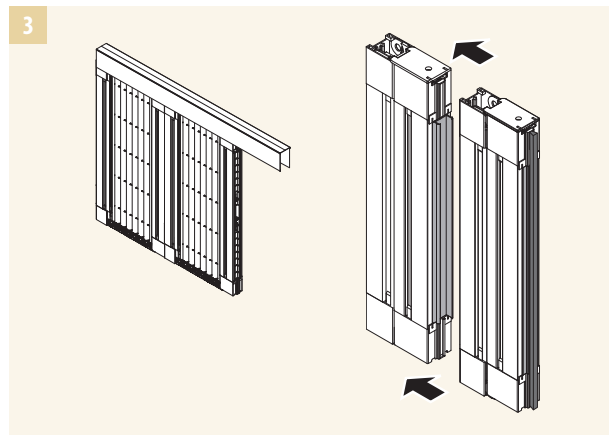
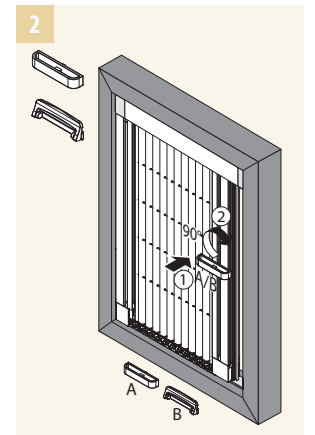
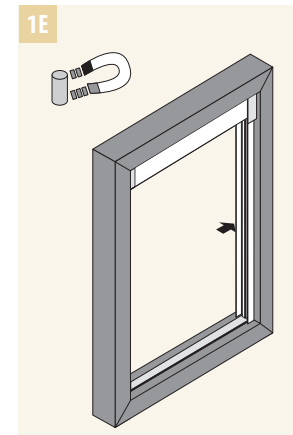
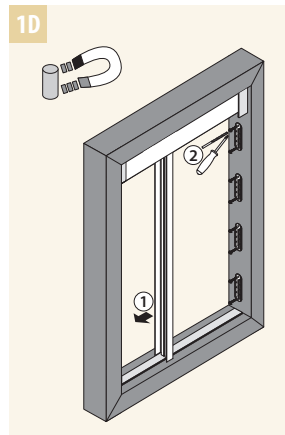
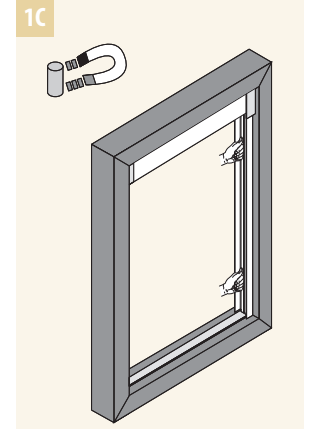
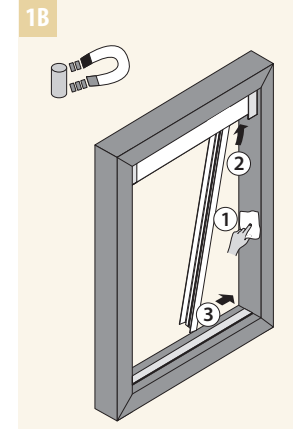
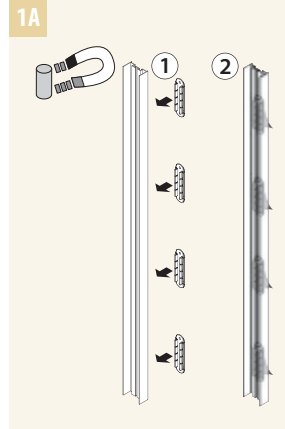

Mounting Instructions

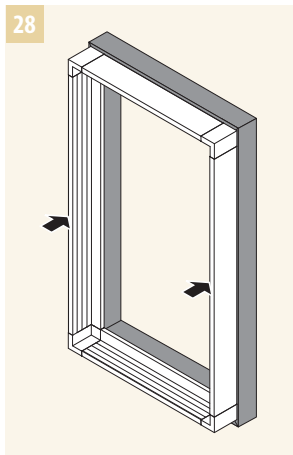
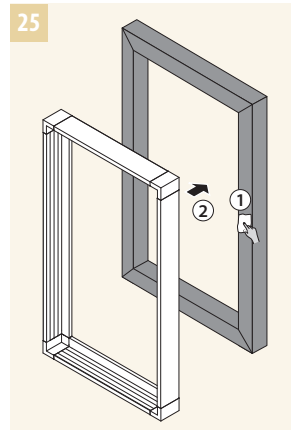
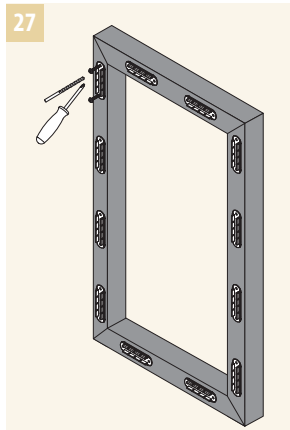
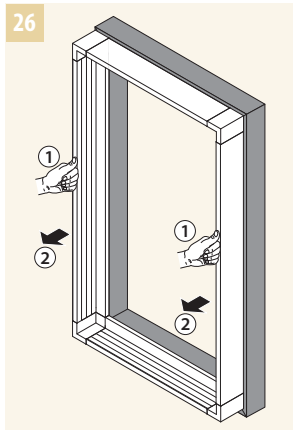
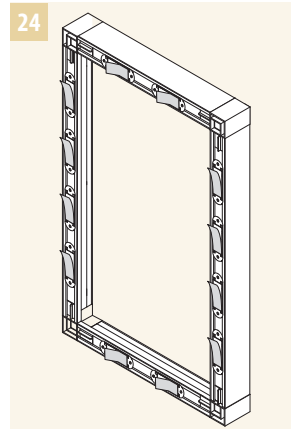
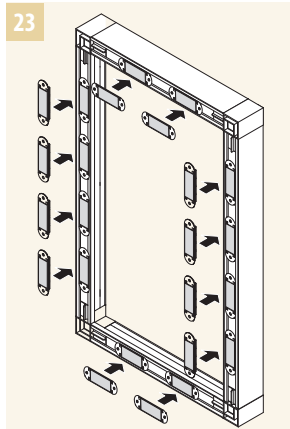
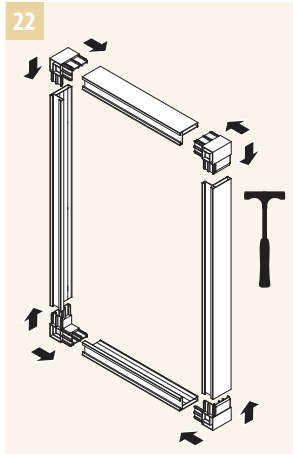

Mounting Instructions

STP

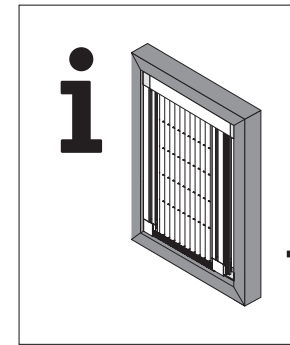

1

STP R

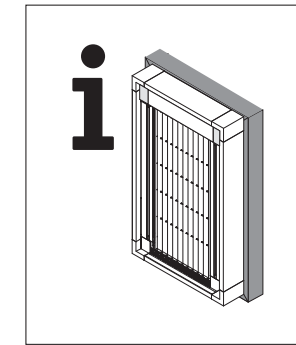

22

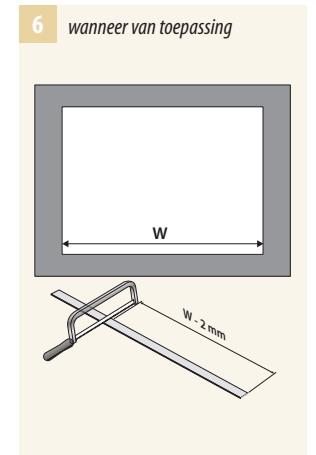
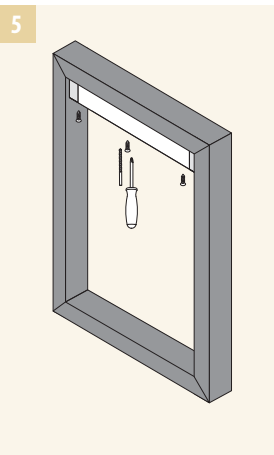
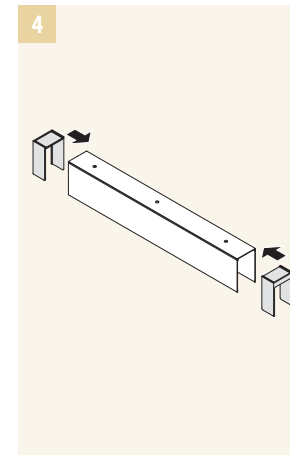
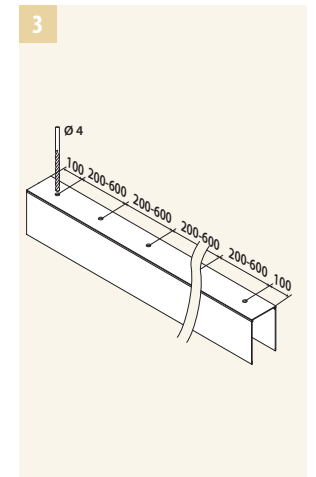
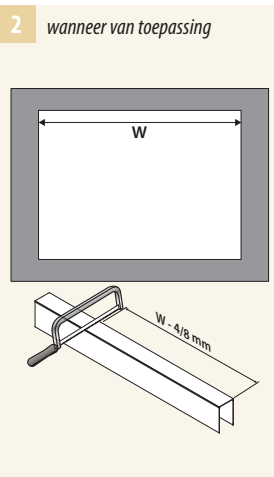
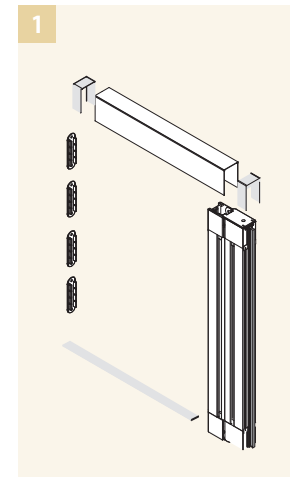

Mounting Instructions

